



AIRTREND Limited  
Predstavništvo u Beogradu  
Kumanovska 14, 11000 Beograd  
Tel: 011/3836886, 3085740  
Faks: 011/3444113  
e-mail: [gobrid@eunet.rs](mailto:gobrid@eunet.rs)  
web: [www.airtrend.rs](http://www.airtrend.rs)

ENERGY EFFICIENT VENTILATION

Östberg is one of the leading producers of radial fans in the world. In the early 1970s, the founder and owner of the company designed the first circular and rectangular in-line radial duct fans in history with external rotor motors and straight-through airflow (180°). We have continued to develop new products and today offer a wide product range of centrifugal in-line duct fans, roof fans, wall fans and energy recovery units. Our goal is to always offer the highest-quality products at competitive prices. The company is certified according to the quality and environment standards ISO 9001 and ISO 14001. These high demands guarantee an efficient and rational production of high-standard fans. All our fans are tested before delivery, which gives us 100% control of production. Air quality directly affects the way we feel, not only physically but also mentally. Therefore use high-quality products from Östberg in order to achieve a healthy indoor climate with energy-efficient ventilation.



The following two symbols are used in this catalogue:



Products marked with the AC and EC symbols are approved for use in the EU, EFTA & EEA countries.

INSIDE WALL MOUNTING

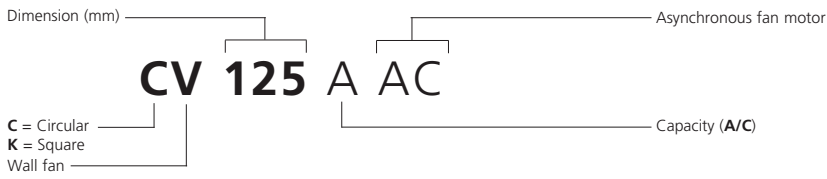

**CV AND KV** ..... 262

The CV and KV are two ranges of wall mounted fans in six different sizes, each containing two different capacities. The CV has a circular backing plate, while the KV has a square one. This variety combined with ease of positioning allows a wide variety of applications including use in damp environments. CV and KV are available with AC motor. Airflows up to 1.760 m<sup>3</sup>/h (0.49 m<sup>3</sup>/s).

EXTERNAL WALL MOUNTING

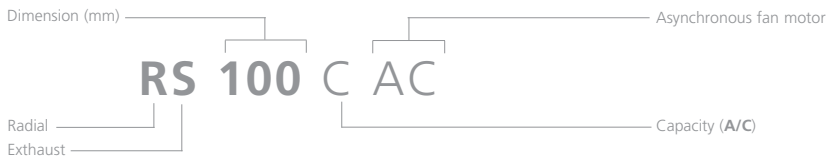

**RS** ..... 276

The RS is a range of exhaust fans designed for mounting on external wall. The casing are manufactured from painted galvanized steel for higher durability. RS is available with AC motor. Airflows up to 850 m<sup>3</sup>/h (0.24 m<sup>3</sup>/s).

# WALL FAN WITH CIRCULAR CONNECTION

## CV/KV 100 A AC



- Wall fan with circular inlet connection.
- CV has a circular mounting plate and KV has a square one.
- Proven performance and reliability.
- Compact with high capacity and efficiency.
- Suitable for a wide variety of applications.
- The power consumption at highest total efficiency is below 125W and is not subject to the ErP directive.
- Impeller with backward curved blades.
- The external rotor motor has maintenance-free sealed ball-bearings.
- Integrated approved thermal motor protection.

- Motor has insulation class F.
- Enclosure class of the fan is IP 44.
- Junction box has enclosure class IP 54.
- For speed control a transformer or electronic speed controller can be connected.
- Fan housing is manufactured from galvanized sheet steel.
- The fan is intended to be installed in a duct system, mounted on the inside wall.
- Easy installation in any position.
- Can be used in damp environments.

### ACCESSORIES

- Mounting clamp, MK 100, simplifies the connection to duct and absorb vibrations
- Safety grill, BSV/BSR 100/250
- Wall grid, YG 250
- Louvre shutter, VK 250
- Backdraught shutter, RSK 100, for mounting in duct on the inlet side
- Transformer VRDE 1.5, VRTE C
- Electronic speed controller, VRS 0.5

### PRESSURE/FLOW

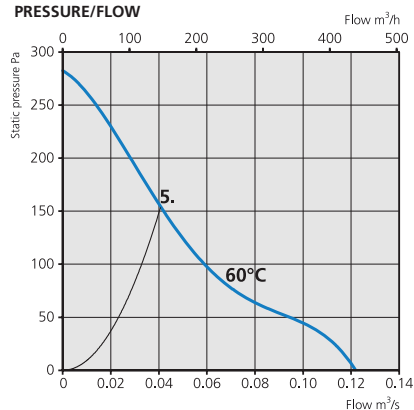

### POWER/FLOW

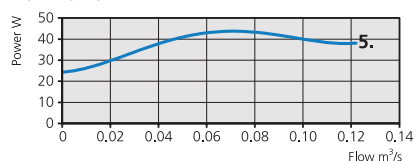

### SFP

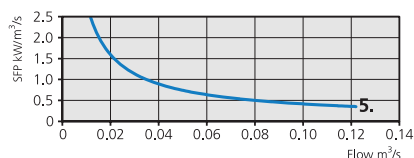

### TRANSFORMER STEPS

1. 80V
2. 110V
3. 135V
4. 165V
5. 230V

Measured when connected to duct on the inlet.

### TECHNICAL DATA

CV/KV 100 A AC	Art.no. 7110013 / 7100086
Voltage	230/50 V/Hz
Voltage range	220-240 / 50/60 V/Hz
Phase	1 ~
Current	0.18 A
Power	41 W
Speed	1730 rpm
Capacitor	3 µF
Max. temperature of transported air	60 C°
Max. temperature of transported air when speed controlled	60 C°
Sound pressure level at 3 m	36 dB(A)
Weight	2.3 kg
Wiring diagram	4040002

### SOUND DATA

	L <sub>PA</sub>	L <sub>WA</sub> tot dB (A)	63	125	250	500	1K	2K	4K	8K
5. Surrounding 230V	36	43	35	21	33	35	39	37	37	31
5. Inlet 230V		66	45	56	64	60	58	52	45	38

### DIMENSIONS (mm)

#### CV

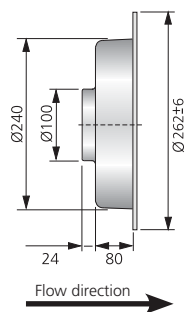

#### KV

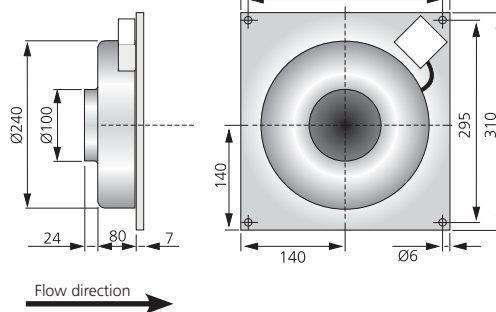

# WALL FAN WITH CIRCULAR CONNECTION

## CV/KV 100 C AC



### ACCESSORIES

- Mounting clamp, MK 100, simplifies the connection to duct and absorb vibrations
- Safety grill, BSV/BSR 100/250
- Wall grid, YG 250
- Louvre shutter, VK 250
- Backdraught shutter, RSK 100, for mounting in duct on the inlet side
- Transformer VRDE 1.5, VRTE C
- Electronic speed controller, VRS 0.5

- Wall fan with circular inlet connection.
- CV has a circular mounting plate and KV has a square one.
- Proven performance and reliability.
- Compact with high capacity and efficiency.
- Suitable for a wide variety of applications.
- The power consumption at highest total efficiency is below 125W and is not subject to the ErP directive.
- Impeller with backward curved blades.
- The external rotor motor has maintenance-free sealed ball-bearings.
- Integrated approved thermal motor protection.

- Motor has insulation class F.
- Enclosure class of the fan is IP 44.
- Junction box has enclosure class IP 54.
- For speed control a transformer or electronic speed controller can be connected.
- Fan housing is manufactured from galvanized sheet steel.
- The fan is intended to be installed in a duct system, mounted on the inside wall.
- Easy installation in any position.
- Can be used in damp environments.

### TECHNICAL DATA

CV/KV 100 C AC	Art.no. 7110014 / 7100090
Voltage	230/50 V/Hz
Voltage range	220-240 / 50/60 V/Hz
Phase	1 ~
Current	0.27 A
Power	62 W
Speed	2530 rpm
Capacitor	2 µF
Max. temperature of transported air	60 °C
Max. temperature of transported air when speed controlled	60 °C
Sound pressure level at 3 m	42 dB(A)
Weight	2.3 kg
Wiring diagram	4040001

### SOUND DATA

	L <sub>PA</sub>	L <sub>WA</sub> tot dB (A)	63	125	250	500	1K	2K	4K	8K
5. Surrounding 230V	42	49	34	23	40	40	44	42	44	38
5. Inlet 230V		70	50	61	66	65	65	59	52	46

### PRESSURE/FLOW

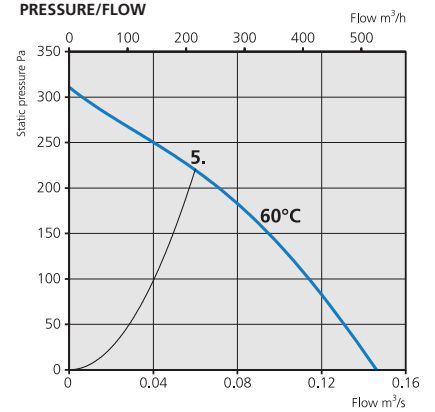

### POWER/FLOW

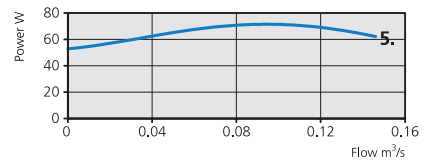

### SFP

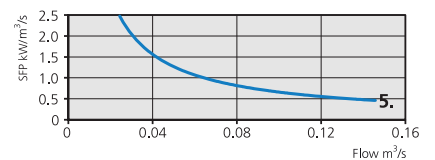

### DIMENSIONS (mm)

#### CV

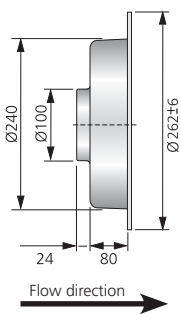

#### KV

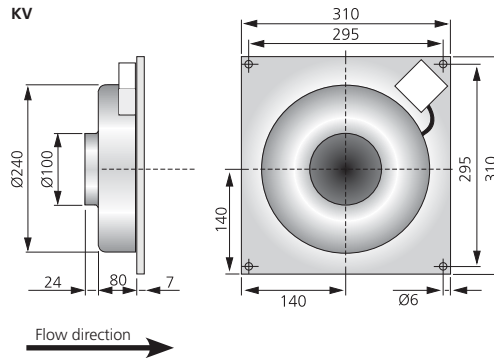

### TRANSFORMER STEPS

1. 80V
2. 110V
3. 135V
4. 165V
5. 230V

Measured when connected to duct on the inlet.

# WALL FAN WITH CIRCULAR CONNECTION

## CV/KV 125 A AC



- Wall fan with circular inlet connection.
- CV has a circular mounting plate and KV has a square one.
- Proven performance and reliability.
- Compact with high capacity and efficiency.
- Suitable for a wide variety of applications.
- The power consumption at highest total efficiency is below 125W and is not subject to the ErP directive.
- Impeller with backward curved blades.
- The external rotor motor has maintenance-free sealed ball-bearings.
- Integrated approved thermal motor protection.

- Motor has insulation class F.
- Enclosure class of the fan is IP 44.
- Junction box has enclosure class IP 54.
- For speed control a transformer or electronic speed controller can be connected.
- Fan housing is manufactured from galvanized sheet steel.
- The fan is intended to be installed in a duct system, mounted on the inside wall.
- Easy installation in any position.
- Can be used in damp environments.

### ACCESSORIES

- Mounting clamp, MK 125, simplifies the connection to duct and absorb vibrations
- Safety grill, BSV/BSR 125/250
- Wall grid, YG 250
- Louvre shutter, VK 250
- Backdraught shutter, RSK 125, for mounting in duct on the inlet side
- Transformer VRDE 1.5, VRTE C
- Electronic speed controller, VRS 0.5

### PRESSURE/FLOW

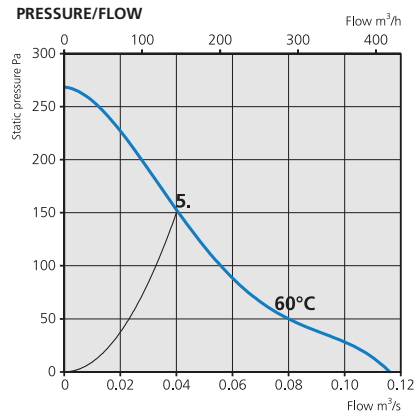

### POWER/FLOW

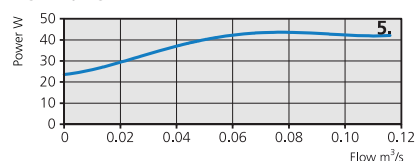

### SFP

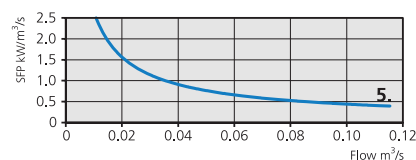

### TRANSFORMER STEPS

1. 80V
2. 110V
3. 135V
4. 165V
5. 230V

Measured when connected to duct on the inlet.

### TECHNICAL DATA

CV/KV 125 A AC	Art.no. 7110015 / 7100094
Voltage	230/50 V/Hz
Voltage range	220-240 / 50/60 V/Hz
Phase	1 ~
Current	0.18 A
Power	40 W
Speed	1640 rpm
Capacitor	3 µF
Max. temperature of transported air	60 C°
Max. temperature of transported air when speed controlled	60 C°
Sound pressure level at 3 m	36 dB(A)
Weight	2.2 kg
Wiring diagram	4040002

### SOUND DATA

	L <sub>PA</sub>	L <sub>WA</sub> tot dB (A)	63	125	250	500	1K	2K	4K	8K
5. Surrounding 230V	36	43	35	20	35	34	38	38	36	30
5. Inlet 230V		67	44	51	66	60	56	52	47	39

### DIMENSIONS (mm)

#### CV

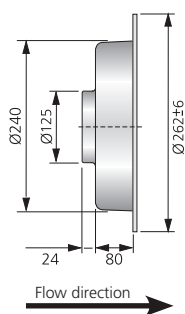

#### KV

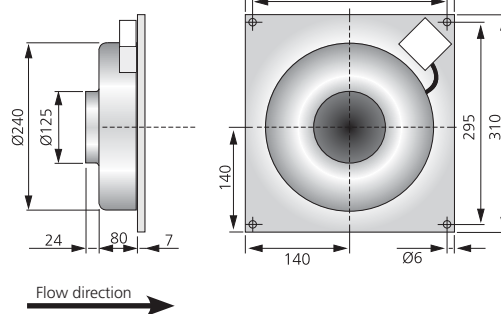

# WALL FAN WITH CIRCULAR CONNECTION

## CV/KV 125 C AC



### ACCESSORIES

- Mounting clamp, MK 125, simplifies the connection to duct and absorb vibrations
- Safety grill, BSV/BSR 125/250
- Wall grid, YG 250
- Louvre shutter, VK 250
- Backdraught shutter, RSK 125, for mounting in duct on the inlet side
- Transformer VRDE 1.5, VRTE C
- Electronic speed controller, VRS 0.5

- Wall fan with circular inlet connection.
- CV has a circular mounting plate and KV has a square one.
- Proven performance and reliability.
- Compact with high capacity and efficiency.
- Suitable for a wide variety of applications.
- The power consumption at highest total efficiency is below 125W and is not subject to the ErP directive.
- Impeller with backward curved blades.
- The external rotor motor has maintenance-free sealed ball-bearings.
- Integrated approved thermal motor protection.

- Motor has insulation class F.
- Enclosure class of the fan is IP 44.
- Junction box has enclosure class IP 54.
- For speed control a transformer or electronic speed controller can be connected.
- Fan housing is manufactured from galvanized sheet steel.
- The fan is intended to be installed in a duct system, mounted on the inside wall.
- Easy installation in any position.
- Can be used in damp environments.

### TECHNICAL DATA

CV/KV 125 C AC	Art.no. 7110016 / 7100098
Voltage	230/50 V/Hz
Voltage range	220-240 / 50/60 V/Hz
Phase	1 ~
Current	0.27 A
Power	62 W
Speed	2480 rpm
Capacitor	2 µF
Max. temperature of transported air	70 C°
Max. temperature of transported air when speed controlled	70 C°
Sound pressure level at 3 m	42 dB(A)
Weight	2.2 kg
Wiring diagram	4040001

### SOUND DATA

	L <sub>PA</sub>	L <sub>WA</sub> tot dB (A)	63	125	250	500	1K	2K	4K	8K
5. Surrounding 230V	42	49	36	25	39	39	44	43	45	36
5. Inlet 230V		70	49	55	64	67	64	60	55	48

### PRESSURE/FLOW

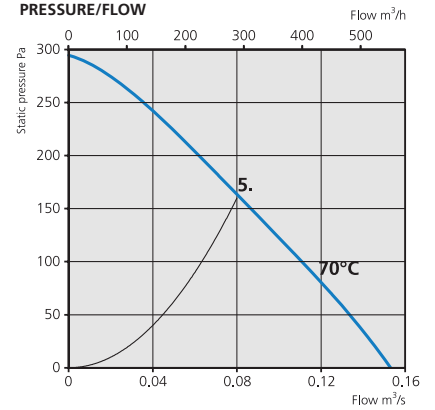

### POWER/FLOW

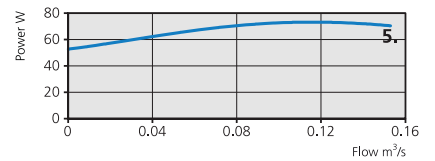

### SFP

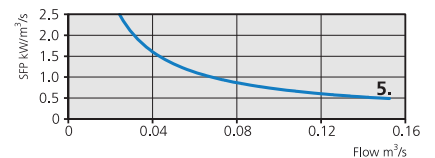

### DIMENSIONS (mm)

#### CV

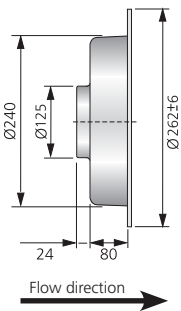

#### KV

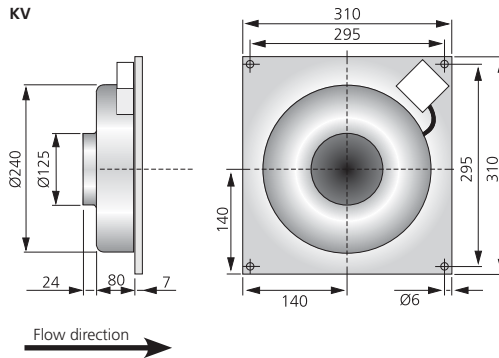

### TRANSFORMER STEPS

1. 80V
2. 110V
3. 135V
4. 165V
5. 230V

Measured when connected to duct on the inlet.

# WALL FAN WITH CIRCULAR CONNECTION

## CV/KV 160 B AC



- Wall fan with circular inlet connection.
- CV has a circular mounting plate and KV has a square one.
- Proven performance and reliability.
- Compact with high capacity and efficiency.
- Suitable for a wide variety of applications.
- The power consumption at highest total efficiency is below 125W and is not subject to the ErP directive.
- Impeller with backward curved blades.
- The external rotor motor has maintenance-free sealed ball-bearings.
- Integrated approved thermal motor protection.

- Motor has insulation class F.
- Enclosure class of the fan is IP 44.
- Junction box has enclosure class IP 54.
- For speed control a transformer or electronic speed controller can be connected.
- Fan housing is manufactured from galvanized sheet steel.
- The fan is intended to be installed in a duct system, mounted on the inside wall.
- Easy installation in any position.
- Can be used in damp environments.

### ACCESSORIES

- Mounting clamp, MK 160, simplifies the connection to duct and absorb vibrations
- Safety grill, BSV/BSR 160/315
- Wall grid, YG 250
- Louvre shutter, VK 250
- Backdraught shutter, RSK 160, for mounting in duct on the inlet side
- Transformer VRDE 1.5, VRTE C
- Electronic speed controller, VRS 0.5

### PRESSURE/FLOW

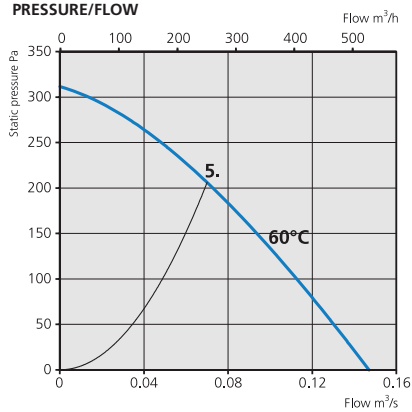

### POWER/FLOW

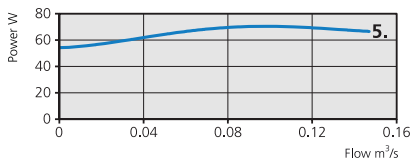

### SFP

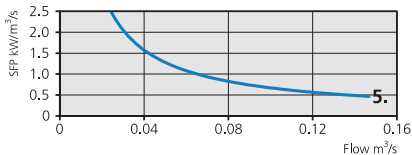

### TRANSFORMER STEPS

1. 80V
2. 110V
3. 135V
4. 165V
5. 230V

Measured when connected to duct on the inlet.

### TECHNICAL DATA

CV/KV 160 B AC	Art.no. 7110017 / 7100102
Voltage	230/50 V/Hz
Voltage range	220-240 / 50/60 V/Hz
Phase	1 ~
Current	0.27 A
Power	62 W
Speed	2540 rpm
Capacitor	2 µF
Max. temperature of transported air	60 C°
Max. temperature of transported air when speed controlled	60 C°
Sound pressure level at 3 m	42 dB(A)
Weight	2.4 kg
Wiring diagram	4040001

### SOUND DATA

	L <sub>pA</sub>	L <sub>WA</sub> tot dB (A)	63	125	250	500	1K	2K	4K	8K
5. Surrounding 230V	42	49	35	24	39	40	45	44	44	32
5. Inlet 230V		69	48	54	64	65	63	58	53	48

### DIMENSIONS (mm)

#### CV

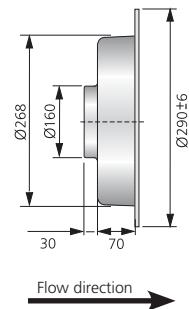

#### KV

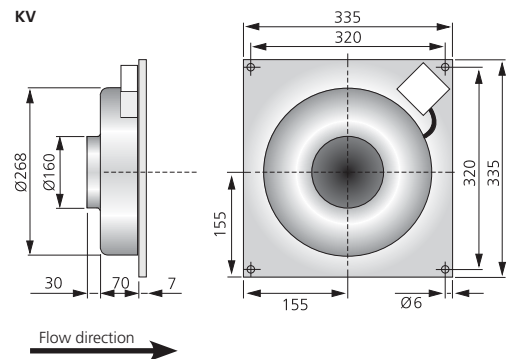





# WALL FAN WITH CIRCULAR CONNECTION

## CV/KV 160 C AC

### ACCESSORIES

- Mounting clamp, MK 160, simplifies the connection to duct and absorb vibrations
- Safety grill, BSV/BSR 160/355
- Louvre shutter, VK 355
- Backdraught shutter, RSK 160, for mounting in duct on the inlet side
- Transformer VRDE 1.5, VRTE C
- Electronic speed controller, VRS 0.5

- Wall fan with circular inlet connection.
- CV has a circular mounting plate and KV has a square one.
- Proven performance and reliability.
- Compact with high capacity and efficiency.
- Suitable for a wide variety of applications.
- The power consumption at highest total efficiency is below 125W and is not subject to the ErP directive.
- Impeller with backward curved blades.
- The external rotor motor has maintenance-free sealed ball-bearings.
- Integrated approved thermal motor protection.

- Motor has insulation class F.
- Enclosure class of the fan is IP 44.
- Junction box has enclosure class IP 54.
- For speed control a transformer or electronic speed controller can be connected.
- Fan housing is manufactured from galvanized sheet steel.
- The fan is intended to be installed in a duct system, mounted on the inside wall.
- Easy installation in any position.
- Can be used in damp environments.

### TECHNICAL DATA

CV/KV 160 C AC	Art.no. 7110018 / 7100106
Voltage	230/50 V/Hz
Voltage range	220-240 / 50/60 V/Hz
Phase	1 ~
Current	0.44 A
Power	105 W
Speed	2480 rpm
Capacitor	3 µF
Max. temperature of transported air	65 °C
Max. temperature of transported air when speed controlled	65 °C
Sound pressure level at 3 m	49 dB(A)
Weight	3.1 kg
Wiring diagram	4040001

### SOUND DATA

	L <sub>PA</sub>	L <sub>WA</sub> tot dB (A)	63	125	250	500	1K	2K	4K	8K
5. Surrounding 230V	49	56	35	34	42	49	54	47	48	35
5. Inlet 230V		73	52	60	64	68	69	64	64	54

### PRESSURE/FLOW

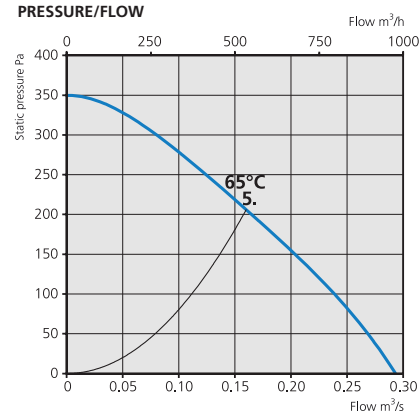

### POWER/FLOW

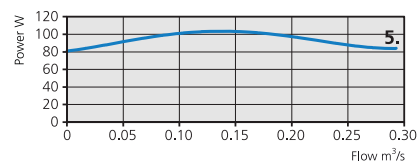

### SFP

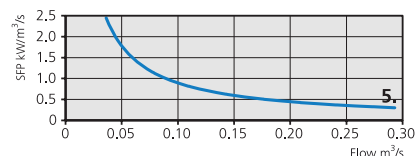

### DIMENSIONS (mm)

#### CV

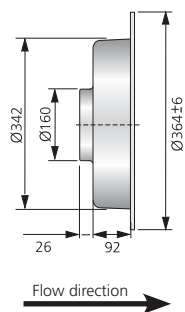

#### KV

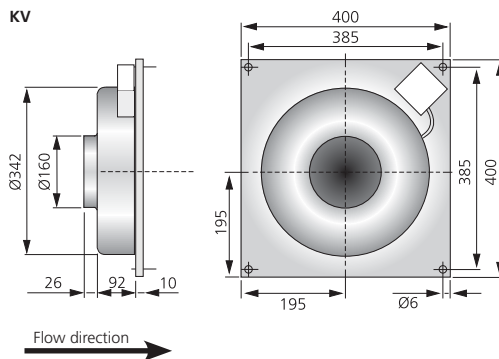

### TRANSFORMER STEPS

1. 80V
2. 110V
3. 135V
4. 165V
5. 230V

Measured when connected to duct on the inlet.

# WALL FAN WITH CIRCULAR CONNECTION

## CV/KV 200 A AC



- Wall fan with circular inlet connection.
- CV has a circular mounting plate and KV has a square one.
- Proven performance and reliability.
- Compact with high capacity and efficiency.
- Suitable for a wide variety of applications.
- The power consumption at highest total efficiency is below 125W and is not subject to the ErP directive.
- Impeller with backward curved blades.
- The external rotor motor has maintenance-free sealed ball-bearings.
- Integrated approved thermal motor protection.

- Motor has insulation class F.
- Enclosure class of the fan is IP 44.
- Junction box has enclosure class IP 54.
- For speed control a transformer or electronic speed controller can be connected.
- Fan housing is manufactured from galvanized sheet steel.
- The fan is intended to be installed in a duct system, mounted on the inside wall.
- Easy installation in any position.
- Can be used in damp environments.

### ACCESSORIES

- Mounting clamp, MK 200, simplifies the connection to duct and absorb vibrations
- Safety grill, BSV/BSR 200/355
- Louvre shutter, VK 355
- Backdraught shutter, RSK 200, for mounting in duct on the inlet side
- Transformer VRDE 1.5, VRTE C
- Electronic speed controller, VRS 0.5

### PRESSURE/FLOW

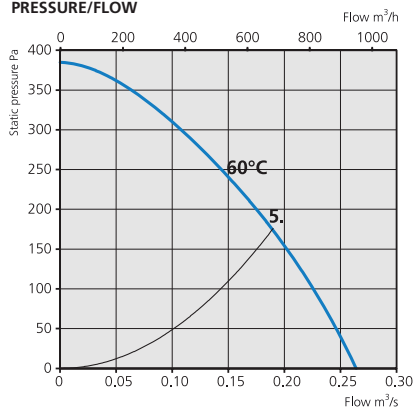

### POWER/FLOW

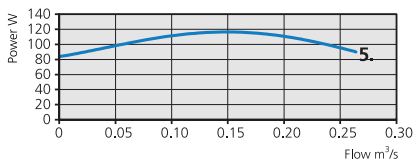

### SFP

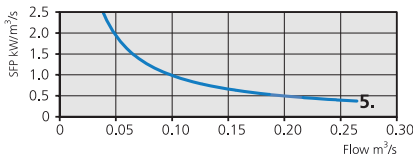

### TRANSFORMER STEPS

1. 80V
2. 110V
3. 135V
4. 165V
5. 230V

Measured when connected to duct on the inlet.

### TECHNICAL DATA

CV/KV 200 A AC	Art.no. 7110019 / 7100110
<b>Voltage</b>	230/50 V/Hz
<b>Voltage range</b>	220-240 / 50/60 V/Hz
<b>Phase</b>	1 ~
<b>Current</b>	0.50 A
<b>Power</b>	115 W
<b>Speed</b>	2580 rpm
<b>Capacitor</b>	4 µF
<b>Max. temperature of transported air</b>	60 C°
<b>Max. temperature of transported air when speed controlled</b>	60 C°
<b>Sound pressure level at 3 m</b>	47 dB(A)
<b>Weight</b>	3.3 kg
<b>Wiring diagram</b>	4040001

### SOUND DATA

	L <sub>PA</sub>	L <sub>WA</sub> tot dB (A)	63	125	250	500	1K	2K	4K	8K
<b>5. Surrounding 230V</b>	47	54	34	31	42	46	50	47	48	34
<b>5. Inlet 230V</b>		72	52	60	64	67	66	64	65	55

### DIMENSIONS (mm)

#### CV

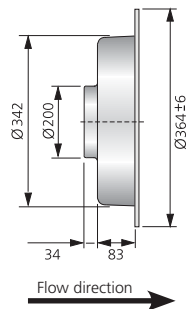

#### KV

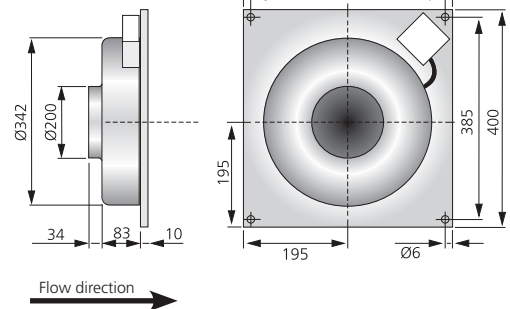



# WALL FAN WITH CIRCULAR CONNECTION

## CV/KV 200 B ErP AC

### ACCESSORIES

- Mounting clamp, MK 200, simplifies the connection to duct and absorb vibrations
- Safety grill, BSV/BSR 200/355
- Louvre shutter, VK 355
- Backdraught shutter, RSK 200, for mounting in duct on the inlet side
- Transformer VRDE 1.5, VRTE C
- Electronic speed controller, VRS 1.0

- Wall fan with circular inlet connection.
- CV has a circular mounting plate and KV has a square one.
- Proven performance and reliability.
- Compact with high capacity and efficiency.
- Suitable for a wide variety of applications.
- The power consumption at highest total efficiency is above 125W and meets the ErP directive.
- Impeller with backward curved blades.
- The external rotor motor has maintenance-free sealed ball-bearings.
- Integrated approved thermal motor protection.

- Motor has insulation class F.
- Enclosure class of the fan is IP 44.
- Junction box has enclosure class IP 54.
- For speed control a transformer or electronic speed controller can be connected.
- Fan housing is manufactured from galvanized sheet steel.
- The fan is intended to be installed in a duct system, mounted on the inside wall.
- Easy installation in any position.
- Can be used in damp environments.

### TECHNICAL DATA

CV/KV 200 B ErP AC	Art.no. 7110063 / 7100122
Voltage	230/50 V/Hz
Voltage range	220-240 / 50/60 V/Hz
Phase	1 ~
Current	0.63 A
Power	144 W
Speed	2720 rpm
Capacitor	5 µF
Max. temperature of transported air	60 C°
Max. temperature of transported air when speed controlled	60 C°
Sound pressure level at 3 m	45 dB(A)
Weight	4.0 kg
Wiring diagram	4040001

### SOUND DATA

	L <sub>PA</sub>	L <sub>WA</sub> tot dB (A)	63	125	250	500	1K	2K	4K	8K
5. Surrounding 230V	45	52	27	34	41	46	48	44	44	35
5. Inlet 230V		75	57	63	70	69	66	64	61	59
4. Inlet 165V		71	53	61	67	65	62	61	59	55
3. Inlet 135V		65	48	55	61	57	53	54	54	40
2. Inlet 110V		55	40	52	48	46	42	43	31	23
1. Inlet 80V		49	36	47	40	36	31	25	15	14

### PRESSURE/FLOW

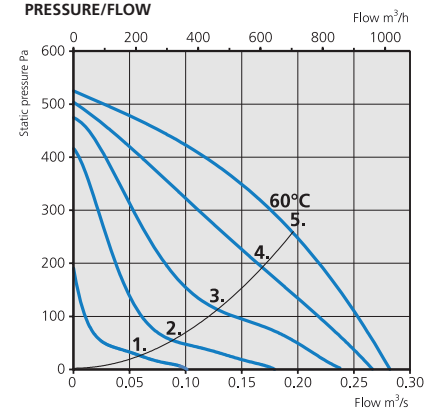

### POWER/FLOW

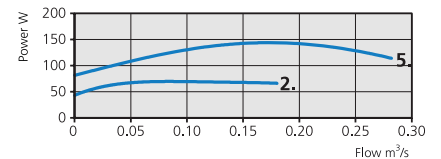

### SFP

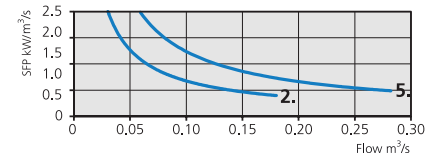

### DIMENSIONS (mm)

#### CV

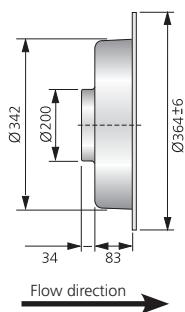

#### KV

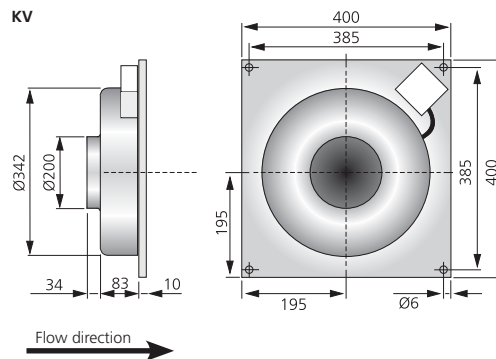

### TRANSFORMER STEPS

1. 80V 2. 110V 3. 135V 4. 165V 5. 230V

Measured when connected to duct on the inlet.

# WALL FAN WITH CIRCULAR CONNECTION

## CV/KV 250 A AC



- Wall fan with circular inlet connection.
- CV has a circular mounting plate and KV has a square one.
- Proven performance and reliability.
- Compact with high capacity and efficiency.
- Suitable for a wide variety of applications.
- The power consumption at highest total efficiency is below 125W and is not subject to the ErP directive.
- Impeller with backward curved blades.
- The external rotor motor has maintenance-free sealed ball-bearings.
- Integrated approved thermal motor protection.

- Motor has insulation class F.
- Enclosure class of the fan is IP 44.
- Junction box has enclosure class IP 54.
- For speed control a transformer or electronic speed controller can be connected.
- Fan housing is manufactured from galvanized sheet steel.
- The fan is intended to be installed in a duct system, mounted on the inside wall.
- Easy installation in any position.
- Can be used in damp environments.

### ACCESSORIES

- Mounting clamp, MK 250, simplifies the connection to duct and absorb vibrations
- Safety grill, BSV/BSR 250/355
- Louvre shutter, VK 355
- Backdraught shutter, RSK 250, for mounting in duct on the inlet side
- Transformer VRDE 1.5, VRTE C
- Electronic speed controller, VRS 1.0

### PRESSURE/FLOW

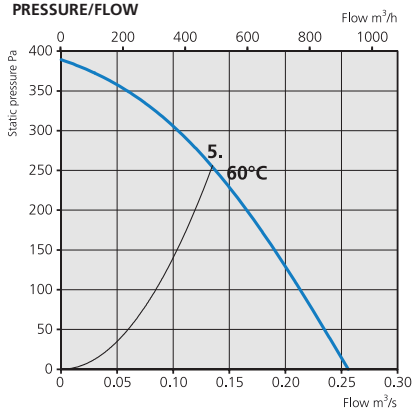

### POWER/FLOW

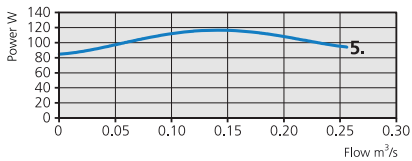

### SFP

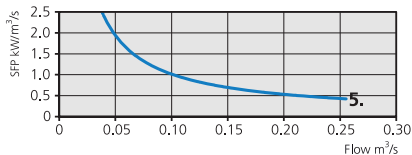

### TRANSFORMER STEPS

1. 80V 2. 110V 3. 135V 4. 165V 5. 230V

Measured when connected to duct on the inlet.

### TECHNICAL DATA

CV/KV 250 A AC	Art.no. 7110021 / 7100118
<b>Voltage</b>	230/50 V/Hz
<b>Voltage range</b>	220-240 / 50/60 V/Hz
<b>Phase</b>	1 ~
<b>Current</b>	0.53 A
<b>Power</b>	120 W
<b>Speed</b>	26580 rpm
<b>Capacitor</b>	4 µF
<b>Max. temperature of transported air</b>	60 C°
<b>Max. temperature of transported air when speed controlled</b>	60 C°
<b>Sound pressure level at 3 m</b>	47 dB(A)
<b>Weight</b>	3.3 kg
<b>Wiring diagram</b>	4040001

### SOUND DATA

	L <sub>PA</sub>	L <sub>WA</sub> tot dB (A)	63	125	250	500	1K	2K	4K	8K
5. Surrounding 230V	47	54	26	30	34	47	52	47	44	38
5. Inlet 230V		74	51	60	67	67	69	68	64	55

### DIMENSIONS (mm)

#### CV

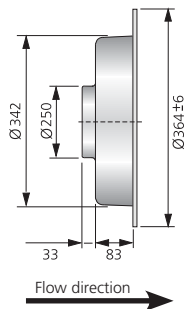

#### KV

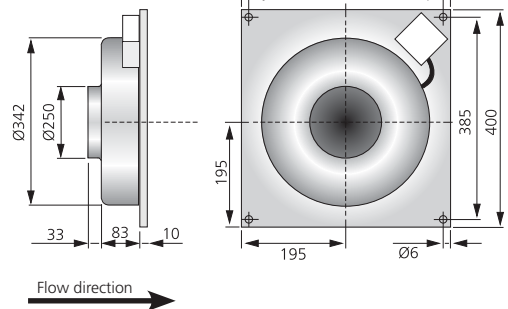



# WALL FAN WITH CIRCULAR CONNECTION

## CV/KV 250 B ErP AC

### ACCESSORIES

- Mounting clamp, MK 250, simplifies the connection to duct and absorb vibrations
- Safety grill, BSV/BSR 250/355
- Louvre shutter, VK 355
- Backdraught shutter, RSK 250, for mounting in duct on the inlet side
- Transformer VRDE 1.5, VRTE C
- Electronic speed controller, VRS 1.0

- Wall fan with circular inlet connection.
- CV has a circular mounting plate and KV has a square one.
- Proven performance and reliability.
- Compact with high capacity and efficiency.
- Suitable for a wide variety of applications.
- The power consumption at highest total efficiency is above 125W and meets the ErP directive.
- Impeller with backward curved blades.
- The external rotor motor has maintenance-free sealed ball-bearings.
- Integrated approved thermal motor protection.

- Motor has insulation class F.
- Enclosure class of the fan is IP 44.
- Junction box has enclosure class IP 54.
- For speed control a transformer or electronic speed controller can be connected.
- Fan housing is manufactured from galvanized sheet steel.
- The fan is intended to be installed in a duct system, mounted on the inside wall.
- Easy installation in any position.
- Can be used in damp environments.

### TECHNICAL DATA

CV/KV 250 B ErP AC	Art.no. 7110068 / 7100139
Voltage	230/50 V/Hz
Voltage range	220-240 / 50/60 V/Hz
Phase	1 ~
Current	0.63 A
Power	146 W
Speed	2740 rpm
Capacitor	5 µF
Max. temperature of transported air	60 C°
Max. temperature of transported air when speed controlled	60 C°
Sound pressure level at 3 m	46 dB(A)
Weight	4.0 kg
Wiring diagram	4040001

### SOUND DATA

	L <sub>PA</sub>	L <sub>WA</sub> tot dB (A)	63	125	250	500	1K	2K	4K	8K
5. Surrounding 230V	46	53	30	31	42	46	49	46	43	38
5. Inlet 230V		75	58	61	71	65	70	65	64	64
4. Inlet 165V		72	51	60	68	61	66	61	61	59
3. Inlet 135V		66	45	52	63	54	57	55	57	41
2. Inlet 110V		55	39	50	48	44	46	49	40	32
1. Inlet 80V		47	35	44	41	34	37	36	17	13

### PRESSURE/FLOW

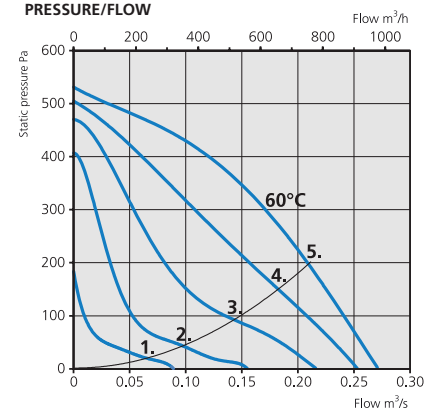

### POWER/FLOW

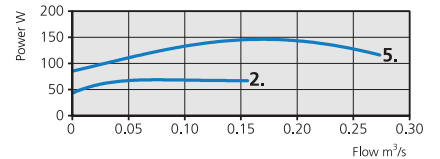

### SFP

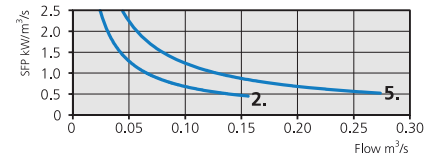

### DIMENSIONS (mm)

#### CV

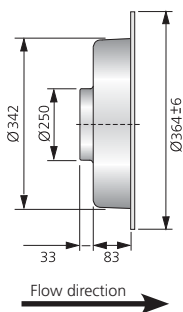

#### KV

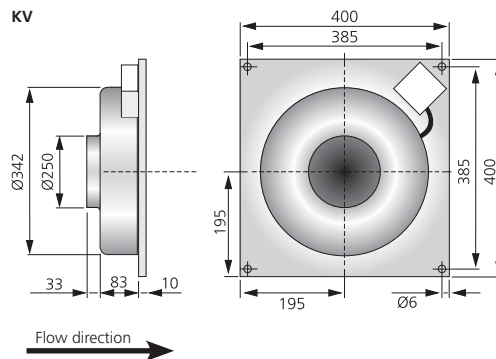

### TRANSFORMER STEPS

1. 80V 2. 110V 3. 135V 4. 165V 5. 230V

Measured when connected to duct on the inlet.

# WALL FAN WITH CIRCULAR CONNECTION

## CV/KV 315 B AC



- Wall fan with circular inlet connection.
- CV has a circular mounting plate and KV has a square one.
- Proven performance and reliability.
- Compact with high capacity and efficiency.
- Suitable for a wide variety of applications.
- Impeller with backward curved blades.
- The external rotor motor has maintenance-free sealed ball-bearings.
- Integrated approved thermal motor protection.
- Motor has insulation class F.
- Enclosure class of the fan is IP 44.

- Junction box has enclosure class IP 54.
- For speed control a transformer or electronic speed controller can be connected.
- Fan housing is manufactured from galvanized sheet steel.
- The fan is intended to be installed in a duct system, mounted on the inside wall.
- Easy installation in any position.
- Can be used in damp environments.
- This product is not approved for use in the EU, EFTA or EEA countries.

### ACCESSORIES

- Mounting clamp, MK 315, simplifies the connection to duct and absorb vibrations
- Safety grill, BSV/BSR 315/400
- Louvre shutter, VK 400
- Backdraught shutter, RSK 315, for mounting in duct on the inlet side
- Transformer VRDE 1.5, VRTE C
- Electronic speed controller, VRS 1.0

### PRESSURE/FLOW

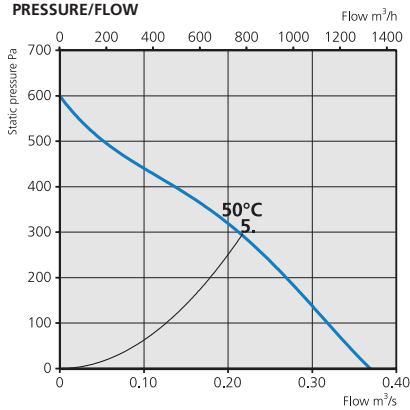

### POWER/FLOW

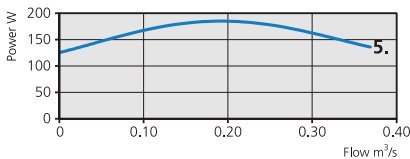

### SFP

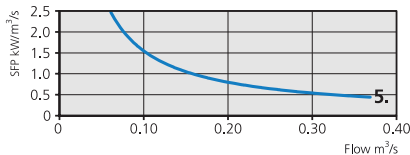

### TRANSFORMER STEPS

1. 80V
2. 110V
3. 135V
4. 165V
5. 230V

Measured when connected to duct on the inlet.

### TECHNICAL DATA

CV/KV 315 B AC	Art.no. 7110024 / 7100135
Voltage	230/50 V/Hz
Voltage range	220-240 / 50/60 V/Hz
Phase	1 ~
Current	0.84 A
Power	190 W
Speed	2465 rpm
Capacitor	5 µF
Max. temperature of transported air	50 C°
Max. temperature of transported air when speed controlled	50 C°
Sound pressure level at 3 m	47 dB(A)
Weight	4.9 kg
Wiring diagram	4040001

### SOUND DATA

	L <sub>pA</sub>	L <sub>WA</sub> tot dB (A)	63	125	250	500	1K	2K	4K	8K
5. Surrounding 230V	47	54	28	35	43	48	49	50	45	41
5. Inlet 230V		74	54	56	61	65	65	70	67	65

### DIMENSIONS (mm)

#### CV

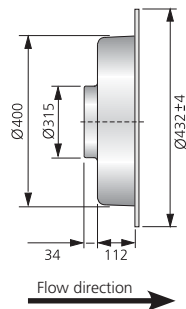

#### KV

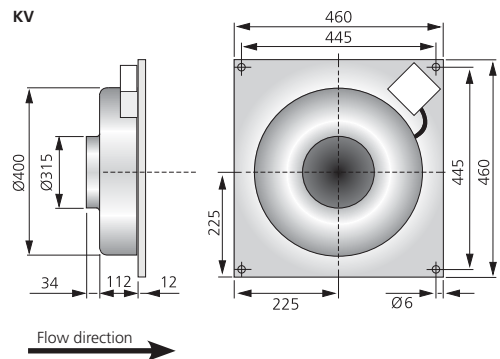



## WALL FAN WITH CIRCULAR CONNECTION

### CV/KV 315 C ErP AC

#### ACCESSORIES

- Mounting clamp, MK 315, simplifies the connection to duct and absorb vibrations
- Safety grill, BSV/BSR 315/400
- Louvre shutter, VK 400
- Backdraught shutter, RSK 315, for mounting in duct on the inlet side
- Transformer VRDE 1.5, VRTE C
- Electronic speed controller, VRS 1.0

- Wall fan with circular inlet connection.
- CV has a circular mounting plate and KV has a square one.
- Proven performance and reliability.
- Compact with high capacity and efficiency.
- Suitable for a wide variety of applications.
- The power consumption at highest total efficiency is above 125W and meets the ErP directive.
- Impeller with backward curved blades.
- The external rotor motor has maintenance-free sealed ball-bearings.
- Integrated approved thermal motor protection.

- Motor has insulation class F.
- Enclosure class of the fan is IP 44.
- Junction box has enclosure class IP 54.
- For speed control a transformer or electronic speed controller can be connected.
- Fan housing is manufactured from galvanized sheet steel.
- The fan is intended to be installed in a duct system, mounted on the inside wall.
- Easy installation in any position.
- Can be used in damp environments.

#### TECHNICAL DATA

CV/KV 315 C ErP AC	Art.no. 7110065 / 7100143
Voltage	230/50 V/Hz
Voltage range	220-240 / 50/60 V/Hz
Phase	1 ~
Current	0.97 A
Power	222 W
Speed	2770 rpm
Capacitor	6 µF
Max. temperature of transported air	50 C°
Max. temperature of transported air when speed controlled	50 C°
Sound pressure level at 3 m	48 dB(A)
Weight	5.2 kg
Wiring diagram	4040001

#### SOUND DATA

	L <sub>PA</sub>	L <sub>WA</sub> tot dB (A)	63	125	250	500	1K	2K	4K	8K
5. Surrounding 230V	48	55	26	44	46	47	46	49	49	38
5. Inlet 230V		74	52	58	63	61	66	68	68	65
4. Inlet 165V		71	50	56	61	59	64	66	65	63

#### PRESSURE/FLOW

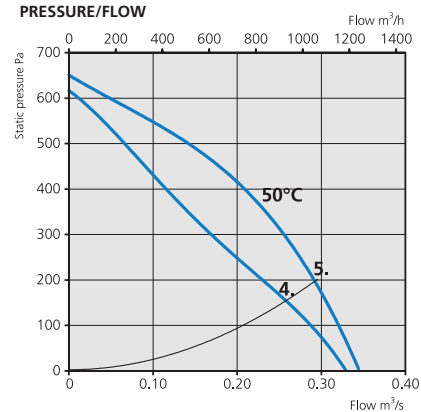

#### POWER/FLOW

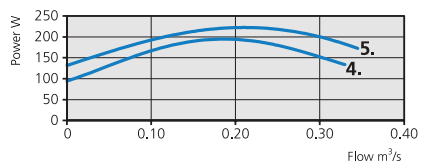

#### SFP

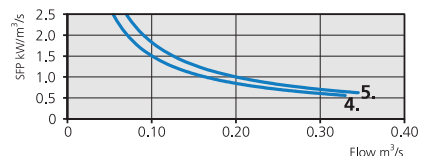

#### DIMENSIONS (mm)

##### CV

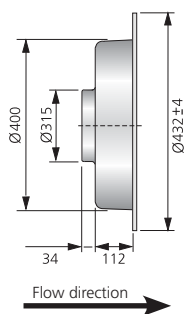

##### KV

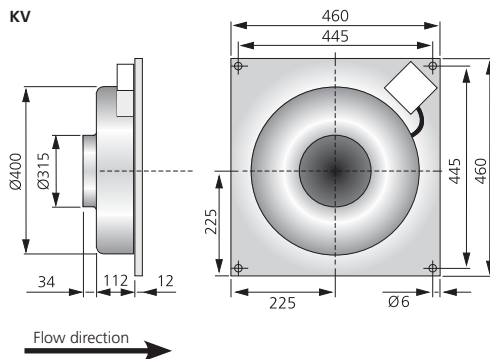

#### TRANSFORMER STEPS

1. 80V 2. 110V 3. 135V 4. 165V 5. 230V  
This product cannot be speed controlled below 165 V.

Measured when connected to duct on the inlet.

# WALL FAN WITH CIRCULAR CONNECTION

## CV/KV 315 C AC



- Wall fan with circular inlet connection.
- CV has a circular mounting plate and KV has a square one.
- Proven performance and reliability.
- Compact with high capacity and efficiency.
- Suitable for a wide variety of applications.
- Impeller with backward curved blades.
- The external rotor motor has maintenance-free sealed ball-bearings.
- Integrated approved thermal motor protection.
- Motor has insulation class F.
- Enclosure class of the fan is IP 44.

- Junction box has enclosure class IP 54.
- For speed control a transformer or electronic speed controller can be connected.
- Fan housing is manufactured from galvanized sheet steel.
- The fan is intended to be installed in a duct system, mounted on the inside wall.
- Easy installation in any position.
- Can be used in damp environments.
- This product is not approved for use in the EU, EFTA or EEA countries.

### ACCESSORIES

- Mounting clamp, MK 315, simplifies the connection to duct and absorb vibrations
- Safety grill, BSV/BSR 315/400
- Louvre shutter, VK 400
- Backdraught shutter, RSK 315, for mounting in duct on the inlet side
- Transformer VRDE 1.5, VRTE 1
- Electronic speed controller, VRS 2.0

### PRESSURE/FLOW

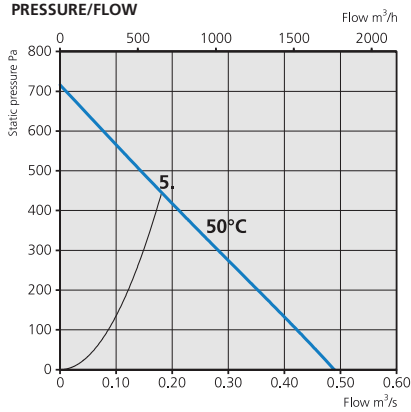

### POWER/FLOW

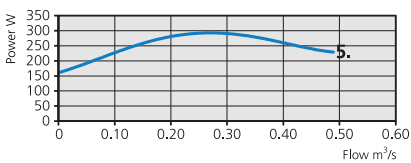

### SFP

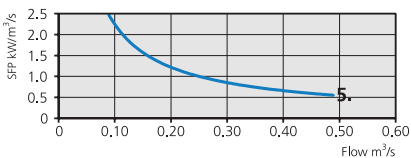

### TRANSFORMER STEPS

1. 80V
2. 110V
3. 135V
4. 165V
5. 230V

Measured when connected to duct on the inlet.

### TECHNICAL DATA

CV/KV 315 C AC	Art.no. 7110023 / 7100130
Voltage	230/50 V/Hz
Voltage range	220-240 / 50/60 V/Hz
Phase	1 ~
Current	1.19 A
Power	274 W
Speed	2500 rpm
Capacitor	8 µF
Max. temperature of transported air	50 C°
Max. temperature of transported air when speed controlled	50 C°
Sound pressure level at 3 m	50 dB(A)
Weight	5.3 kg
Wiring diagram	4040001

### SOUND DATA

	L <sub>pA</sub>	L <sub>WA</sub> tot dB (A)	63	125	250	500	1K	2K	4K	8K
5. Surrounding 230V	50	57	30	35	44	51	51	53	50	43
5. Inlet 230V		75	58	60	67	66	66	72	68	66

### DIMENSIONS (mm)

#### CV

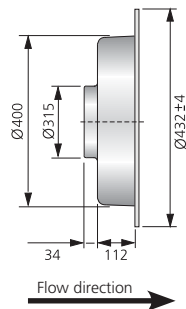

#### KV

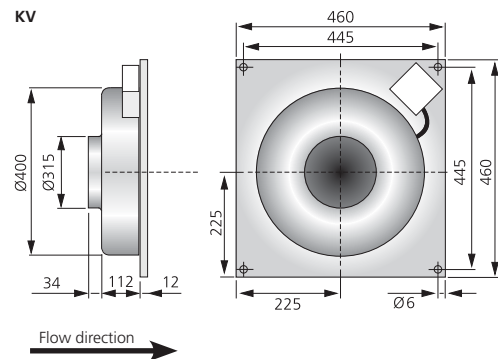



## INSIDE WALL MOUNTING

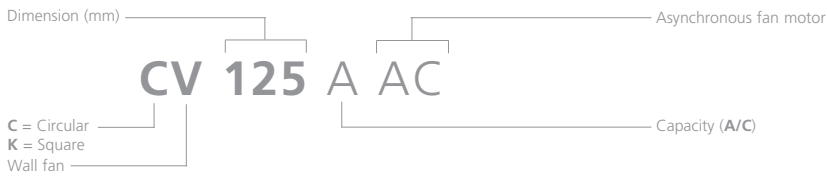

### CV AND KV ..... 262

The CV and KV are two ranges of wall mounted fans in six different sizes, each containing two different capacities. The CV has a circular backing plate, while the KV has a square one. This variety combined with ease of positioning allows a wide variety of applications including use in damp environments.

CV and KV are available with AC motor.

Airflows up to 1.760 m<sup>3</sup>/h (0.49 m<sup>3</sup>/s).

## EXTERNAL WALL MOUNTING

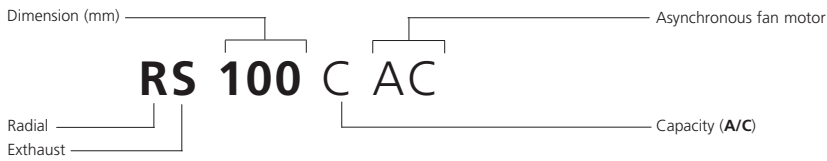

### RS ..... 276

The RS is a range of exhaust fans designed for mounting on external wall. The casing are manufactured from painted galvanized steel for higher durability.

RS is available with AC motor.

Airflows up to 850 m<sup>3</sup>/h (0.24 m<sup>3</sup>/s).

# WALL FAN WITH CIRCULAR CONNECTION

## RS 80 A AC



- Exhaust wall fan with circular inlet connection.
- Designed for mounting on external wall.
- The power consumption at highest total efficiency is below 125W and is not subject to the ErP directive.
- Impeller with backward curved blades.
- The external rotor motor has maintenance-free sealed ball-bearings.
- Integrated approved thermal motor protection.

- Motor has insulation class F.
- Enclosure class of the fan is IP 44.
- Junction box has enclosure class IP 54.
- For speed control a transformer or electronic speed controller can be connected.
- Fan housing is manufactured from galvanized sheet steel.
- Black painted for high durability.

### ACCESSORIES

- Transformer VRDE 1.5, VRTE C
- Electronic speed controller, VRS 0.5

### PRESSURE/FLOW

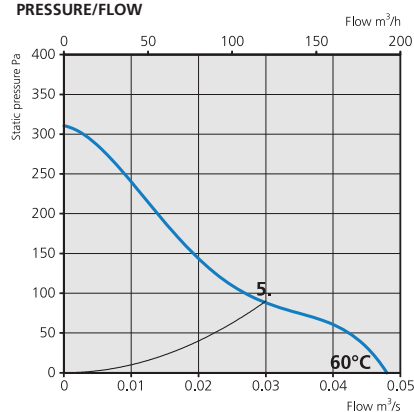

### POWER/FLOW

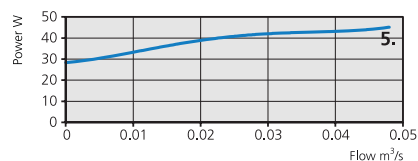

### SFP

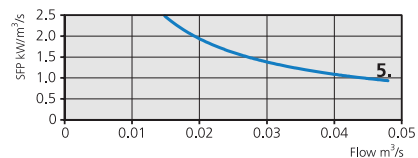

### TRANSFORMER STEPS

1. 80V    2. 110V    3. 135V    4. 165V    5. 230V

### TECHNICAL DATA

<b>RS 80 A AC</b>	<b>Art.no. 7400019</b>
<b>Voltage</b>	230/50 V/Hz
<b>Voltage range</b>	220-240 / 50/60 V/Hz
<b>Phase</b>	1 ~
<b>Current</b>	0.20 A
<b>Power</b>	45 W
<b>Speed</b>	1850 rpm
<b>Capacitor</b>	3 µF
<b>Max. temperature of transported air</b>	60 C°
<b>Max. temperature of transported air when speed controlled</b>	60 C°
<b>Sound pressure level at 3 m</b>	57 dB(A)
<b>Weight</b>	3.4 kg
<b>Wiring diagram</b>	4040002

### SOUND DATA

	$L_{pA}$	$L_{wA}$ tot dB (A)	63	125	250	500	1K	2K	4K	8K
<b>5. Surrounding 230V</b>	57	64	31	39	52	59	62	58	51	43
<b>5. Inlet 230V</b>		66	57	58	60	61	59	55	50	42

### DIMENSIONS (mm)

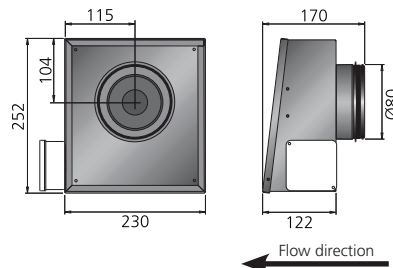

# WALL FAN WITH CIRCULAR CONNECTION

## RS 80 C AC



### ACCESSORIES

- Transformer VRDE 1.5, VRTE C
- Electronic speed controller, VRS 0.5

- Exhaust wall fan with circular inlet connection.
- Designed for mounting on external wall.
- The power consumption at highest total efficiency is below 125W and is not subject to the ErP directive.
- Impeller with backward curved blades.
- The external rotor motor has maintenance-free sealed ball-bearings.
- Integrated approved thermal motor protection.

- Motor has insulation class F.
- Enclosure class of the fan is IP 44.
- Junction box has enclosure class IP 54.
- For speed control a transformer or electronic speed controller can be connected.
- Fan housing is manufactured from galvanized sheet steel.
- Black painted for high durability.

### TECHNICAL DATA

RS 80 C AC	Art.no. 7400020
Voltage	230/50 V/Hz
Voltage range	220-240 / 50/60 V/Hz
Phase	1 ~
Current	0.32 A
Power	62 W
Speed	2520 rpm
Capacitor	2 µF
Max. temperature of transported air	60 C°
Max. temperature of transported air when speed controlled	60 C°
Sound pressure level at 3 m	63 dB(A)
Weight	3.4 kg
Wiring diagram	4040001

### SOUND DATA

	L <sub>pA</sub>	L <sub>WA</sub> tot dB (A)	63	125	250	500	1K	2K	4K	8K
5. Surrounding 230V	63	70	36	43	56	64	67	63	58	49
5. Inlet 230V		72	61	63	66	67	66	61	56	50

### PRESSURE/FLOW

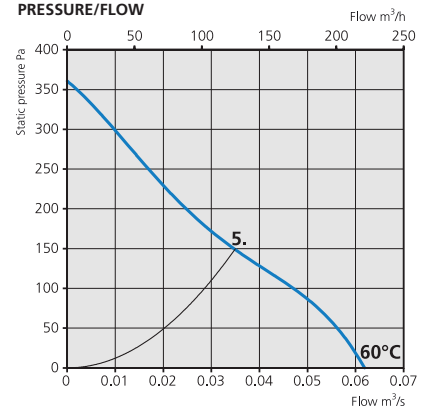

### POWER/FLOW

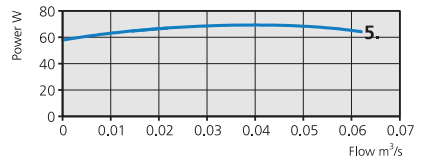

### SFP

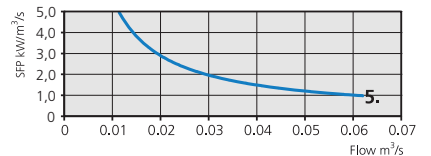

### DIMENSIONS (mm)

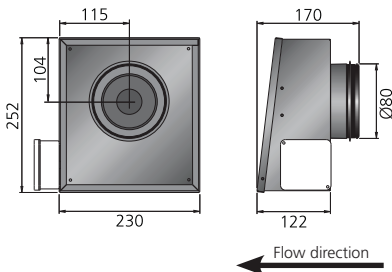

### TRANSFORMER STEPS

1. 80V
2. 110V
3. 135V
4. 165V
5. 230V

# WALL FAN WITH CIRCULAR CONNECTION

## RS 100 A AC



- Exhaust wall fan with circular inlet connection.
- Designed for mounting on external wall.
- The power consumption at highest total efficiency is below 125W and is not subject to the ErP directive.
- Impeller with backward curved blades.
- The external rotor motor has maintenance-free sealed ball-bearings.
- Integrated approved thermal motor protection.

- Motor has insulation class F.
- Enclosure class of the fan is IP 44.
- Junction box has enclosure class IP 54.
- For speed control a transformer or electronic speed controller can be connected.
- Fan housing is manufactured from galvanized sheet steel.
- Black painted for high durability.

### ACCESSORIES

- Transformer VRDE 1.5, VRTE C
- Electronic speed controller, VRS 0.5

### PRESSURE/FLOW

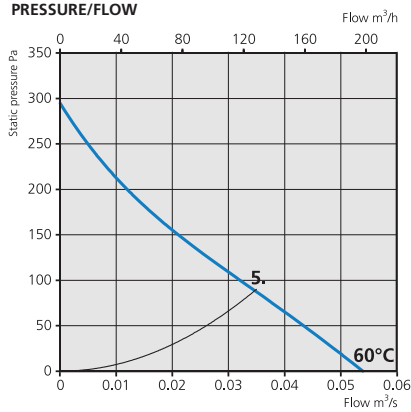

### POWER/FLOW

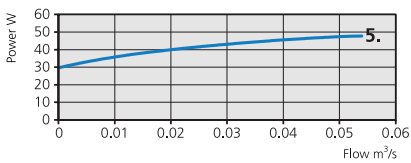

### SFP

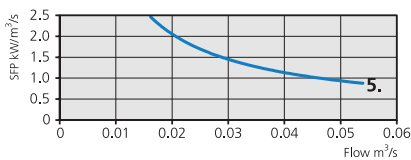

### TRANSFORMER STEPS

1. 80V    2. 110V    3. 135V    4. 165V    5. 230V

### TECHNICAL DATA

RS 100 A AC	Art.no. 7400021
Voltage	230/50 V/Hz
Voltage range	220-240 / 50/60 V/Hz
Phase	1 ~
Current	0.21 A
Power	48 W
Speed	1830 rpm
Capacitor	3 µF
Max. temperature of transported air	60 C°
Max. temperature of transported air when speed controlled	60 C°
Sound pressure level at 3 m	56 dB(A)
Weight	3.4 kg
Wiring diagram	4040002

### SOUND DATA

	L <sub>PA</sub>	L <sub>WA</sub> tot dB (A)	63	125	250	500	1K	2K	4K	8K
5. Surrounding 230V	56	63	30	37	49	56	61	56	50	41
5. Inlet 230V		67	58	59	61	61	60	55	50	42

### DIMENSIONS (mm)

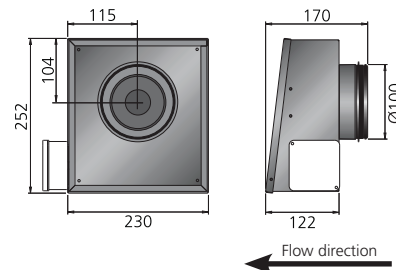

# WALL FAN WITH CIRCULAR CONNECTION

## RS 100 C AC



### ACCESSORIES

- Transformer VRDE 1.5, VRTE C
- Electronic speed controller, VRS 0.5

- Exhaust wall fan with circular inlet connection.
- Designed for mounting on external wall.
- The power consumption at highest total efficiency is below 125W and is not subject to the ErP directive.
- Impeller with backward curved blades.
- The external rotor motor has maintenance-free sealed ball-bearings.
- Integrated approved thermal motor protection.

- Motor has insulation class F.
- Enclosure class of the fan is IP 44.
- Junction box has enclosure class IP 54.
- For speed control a transformer or electronic speed controller can be connected.
- Fan housing is manufactured from galvanized sheet steel.
- Black painted for high durability.

### TECHNICAL DATA

RS 100 C AC	Art.no. 7400022
Voltage	230/50 V/Hz
Voltage range	220-240 / 50/60 V/Hz
Phase	1 ~
Current	0.34 A
Power	62 W
Speed	2490 rpm
Capacitor	2 µF
Max. temperature of transported air	60 C°
Max. temperature of transported air when speed controlled	60 C°
Sound pressure level at 3 m	62 dB(A)
Weight	3.4 kg
Wiring diagram	4040001

### SOUND DATA

	L <sub>PA</sub>	L <sub>WA</sub> tot dB (A)	63	125	250	500	1K	2K	4K	8K
5. Surrounding 230V	62	69	35	43	54	63	67	62	57	48
5. Inlet 230V		73	60	61	66	68	67	62	57	53

### PRESSURE/FLOW

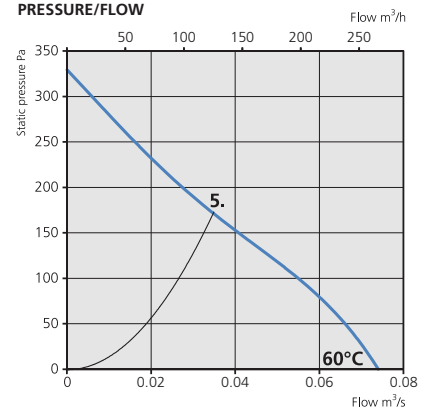

### POWER/FLOW

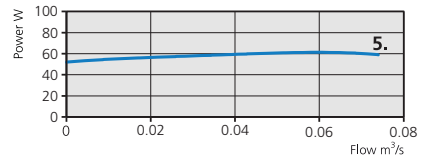

### SFP

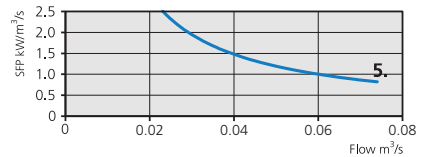

### DIMENSIONS (mm)

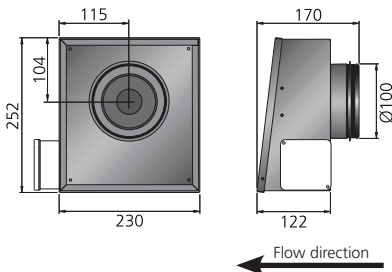

### TRANSFORMER STEPS

1. 80V
2. 110V
3. 135V
4. 165V
5. 230V

# WALL FAN WITH CIRCULAR CONNECTION

## RS 125 A AC



- Exhaust wall fan with circular inlet connection.
- Designed for mounting on external wall.
- The power consumption at highest total efficiency is below 125W and is not subject to the ErP directive.
- Impeller with backward curved blades.
- The external rotor motor has maintenance-free sealed ball-bearings.
- Integrated approved thermal motor protection.

- Motor has insulation class F.
- Enclosure class of the fan is IP 44.
- Junction box has enclosure class IP 54.
- For speed control a transformer or electronic speed controller can be connected.
- Fan housing is manufactured from galvanized sheet steel.
- Black painted for high durability.

### ACCESSORIES

- Transformer VRDE 1.5, VRTE C
- Electronic speed controller, VRS 0.5

### PRESSURE/FLOW

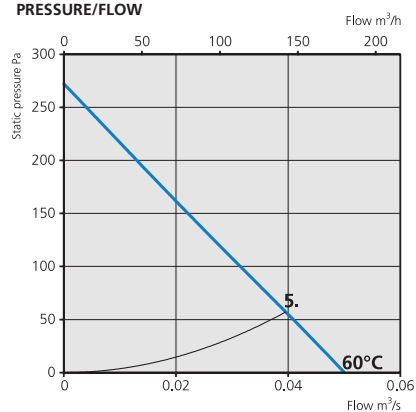

### POWER/FLOW

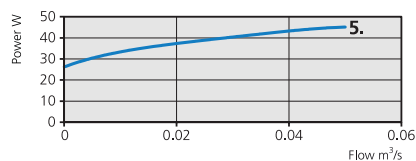

### SFP

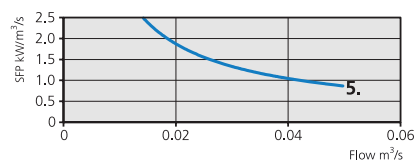

### TRANSFORMER STEPS

1. 80V   2. 110V   3. 135V   4. 165V   5. 230V

### TECHNICAL DATA

RS 125 A AC	Art.no. 7400003
Voltage	230/50 V/Hz
Voltage range	220-240 / 50/60 V/Hz
Phase	1 ~
Current	0.20 A
Power	45 W
Speed	1400 rpm
Capacitor	3 µF
Max. temperature of transported air	60 C°
Max. temperature of transported air when speed controlled	60 C°
Sound pressure level at 3 m	55 dB(A)
Weight	3.4 kg
Wiring diagram	4040002

### SOUND DATA

	L <sub>PA</sub>	L <sub>WA</sub> tot dB (A)	63	125	250	500	1K	2K	4K	8K
5. Surrounding 230V	55	62	41	40	50	56	58	55	44	35
5. Inlet 230V		63	63	54	58	58	56	51	42	28

### DIMENSIONS (mm)

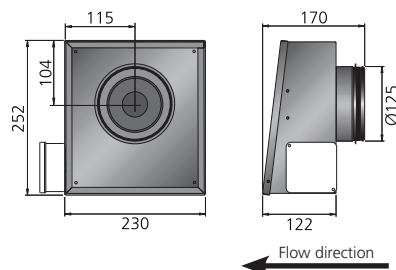

# WALL FAN WITH CIRCULAR CONNECTION

## RS 125 C AC



### ACCESSORIES

- Transformer VRDE 1.5, VRTE C
- Electronic speed controller, VRS 0.5

- Exhaust wall fan with circular inlet connection.
- Designed for mounting on external wall.
- The power consumption at highest total efficiency is below 125W and is not subject to the ErP directive.
- Impeller with backward curved blades.
- The external rotor motor has maintenance-free sealed ball-bearings.
- Integrated approved thermal motor protection.

- Motor has insulation class F.
- Enclosure class of the fan is IP 44.
- Junction box has enclosure class IP 54.
- For speed control a transformer or electronic speed controller can be connected.
- Fan housing is manufactured from galvanized sheet steel.
- Black painted for high durability.

### TECHNICAL DATA

<b>RS 125 C AC</b>	<b>Art.no. 7400004</b>
<b>Voltage</b>	230/50 V/Hz
<b>Voltage range</b>	220-240 / 50/60 V/Hz
<b>Phase</b>	1 ~
<b>Current</b>	0.32 A
<b>Power</b>	62 W
<b>Speed</b>	2460 rpm
<b>Capacitor</b>	2 µF
<b>Max. temperature of transported air</b>	60 C°
<b>Max. temperature of transported air when speed controlled</b>	60 C°
<b>Sound pressure level at 3 m</b>	62 dB(A)
<b>Weight</b>	3.4 kg
<b>Wiring diagram</b>	4040001

### SOUND DATA

	L <sub>pA</sub>	L <sub>WA</sub> tot dB (A)	63	125	250	500	1K	2K	4K	8K
<b>5. Surrounding 230V</b>	62	69	48	41	56	63	66	63	54	46
<b>5. Inlet 230V</b>		70	55	59	63	65	63	59	51	40

### PRESSURE/FLOW

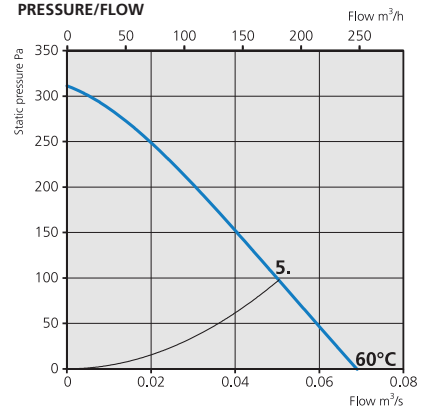

### POWER/FLOW

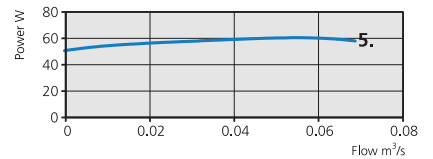

### SFP

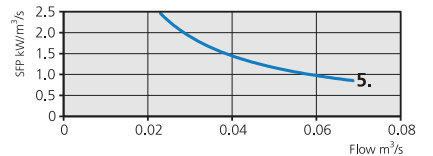

### DIMENSIONS (mm)

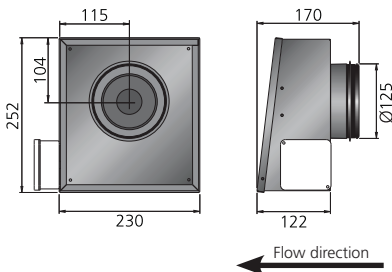

### TRANSFORMER STEPS

1. 80V
2. 110V
3. 135V
4. 165V
5. 230V

# WALL FAN WITH CIRCULAR CONNECTION

## RS 160 A AC



- Exhaust wall fan with circular inlet connection.
- Designed for mounting on external wall.
- The power consumption at highest total efficiency is below 125W and is not subject to the ErP directive.
- Impeller with backward curved blades.
- The external rotor motor has maintenance-free sealed ball-bearings.
- Integrated approved thermal motor protection.

- Motor has insulation class F.
- Enclosure class of the fan is IP 44.
- Junction box has enclosure class IP 54.
- For speed control a transformer or electronic speed controller can be connected.
- Fan housing is manufactured from galvanized sheet steel.
- Black painted for high durability.

### ACCESSORIES

- Transformer VRDE 1.5, VRTE C
- Electronic speed controller, VRS 0.5

### PRESSURE/FLOW

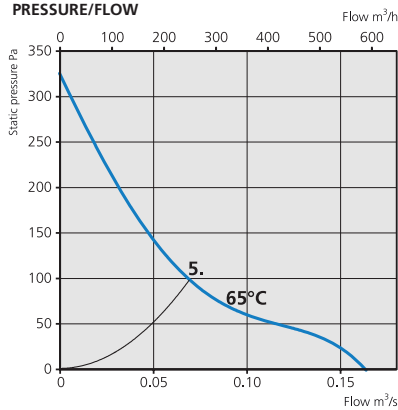

### POWER/FLOW

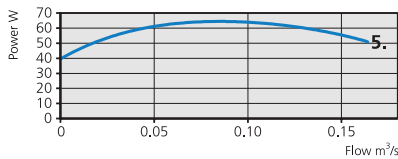

### SFP

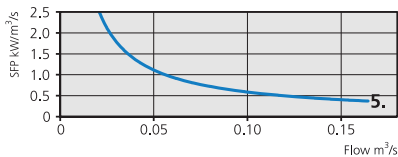

### TRANSFORMER STEPS

1. 80V 2. 110V 3. 135V 4. 165V 5. 230V

### TECHNICAL DATA

RS 160 A AC	Art.no. 7400011
Voltage	230/50 V/Hz
Voltage range	220-240 / 50/60 V/Hz
Phase	1 ~
Current	0.29 A
Power	64 W
Speed	1200 rpm
Capacitor	3 µF
Max. temperature of transported air	65 C°
Max. temperature of transported air when speed controlled	65 C°
Sound pressure level at 3 m	51 dB(A)
Weight	5.2 kg
Wiring diagram	4040002

### SOUND DATA

	L <sub>PA</sub>	L <sub>WA</sub> tot dB (A)	63	125	250	500	1K	2K	4K	8K
5. Surrounding 230V	51	58	48	38	49	53	52	50	40	32
5. Inlet 230V		61	45	53	55	56	54	45	37	19

### DIMENSIONS (mm)

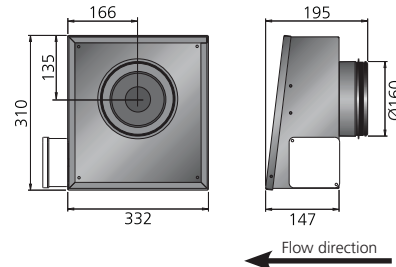



# WALL FAN WITH CIRCULAR CONNECTION

## RS 160 C AC



### ACCESSORIES

- Transformer VRDE 1.5, VRTE C
- Electronic speed controller, VRS 0.5

- Exhaust wall fan with circular inlet connection.
- Designed for mounting on external wall.
- The power consumption at highest total efficiency is below 125W and is not subject to the ErP directive.
- Impeller with backward curved blades.
- The external rotor motor has maintenance-free sealed ball-bearings.
- Integrated approved thermal motor protection.

- Motor has insulation class F.
- Enclosure class of the fan is IP 44.
- Junction box has enclosure class IP 54.
- For speed control a transformer or electronic speed controller can be connected.
- Fan housing is manufactured from galvanized sheet steel.
- Black painted for high durability.

### TECHNICAL DATA

RS 160 C AC	Art.no. 7400012
Voltage	230/50 V/Hz
Voltage range	220-240 / 50/60 V/Hz
Phase	1 ~
Current	0.46 A
Power	104 W
Speed	2480 rpm
Capacitor	3 µF
Max. temperature of transported air	65 °C
Max. temperature of transported air when speed controlled	65 °C
Sound pressure level at 3 m	64 dB(A)
Weight	5.2 kg
Wiring diagram	4040001

### SOUND DATA

	L <sub>pA</sub>	L <sub>WA</sub> tot dB (A)	63	125	250	500	1K	2K	4K	8K
5. Surrounding 230V	64	71	48	44	60	66	66	64	58	46
5. Inlet 230V		73	52	60	66	70	68	59	55	41

### PRESSURE/FLOW

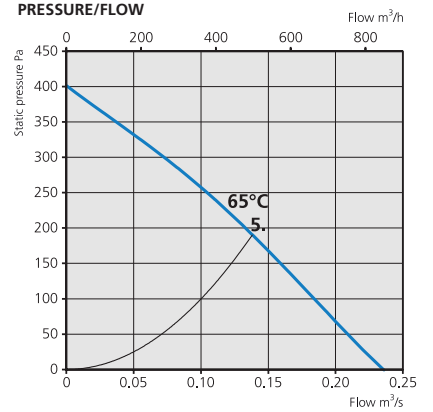

### POWER/FLOW

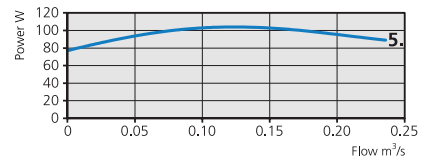

### SFP

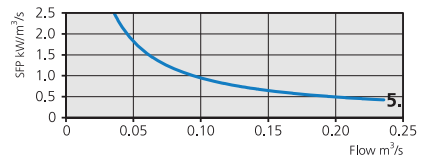

### DIMENSIONS (mm)

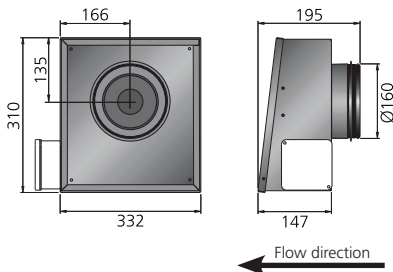

### TRANSFORMER STEPS

1. 80V
2. 110V
3. 135V
4. 165V
5. 230V